



HEAT RECOVERY UNIT WITH EVAPORATIVE COOLING

Models: HRE-20, 45, 55, & 90

INSTALLATION, OPERATION AND MAINTENANCE MANUAL

****WARNING****

DISCONNECT AND SECURE TO THE "OFF" POSITION ALL ELECTRICAL POWER TO THE UNITS PRIOR TO INSPECTION OR SERVICING. FAILURE TO COMPLY WITH THIS SAFETY PRECAUTION COULD RESULT IN SERIOUS INJURY OR DEATH.

****IMPORTANT****

ALL FACTORY PROVIDED LIFTING LUGS MUST BE USED WHEN LIFTING THE UNITS. FAILURE TO COMPLY WITH THIS SAFETY PRECAUTION INJURY COULD RESULT IN PROPERTY DAMAGE, SERIOUS INJURY OR DEATH.

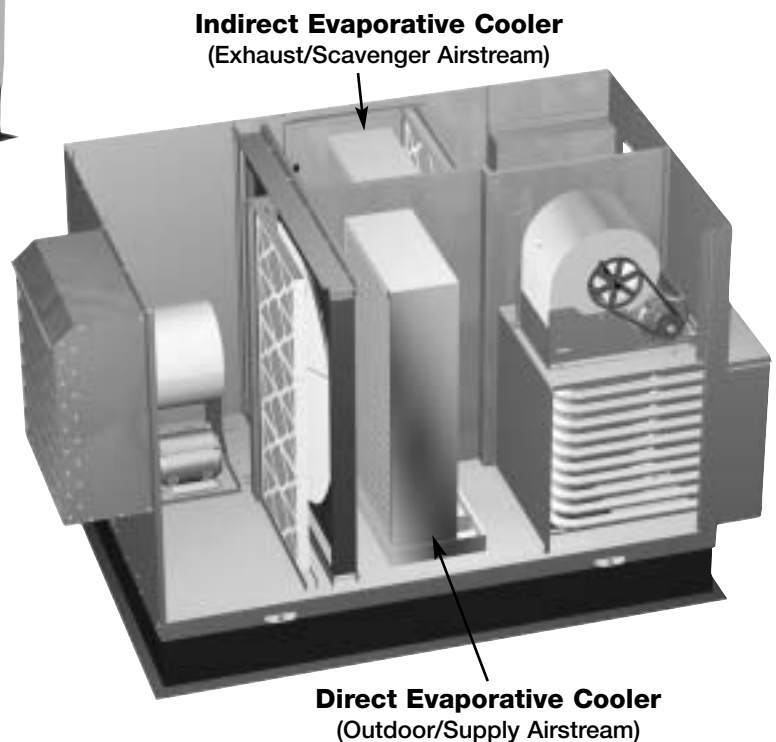

TABLE OF CONTENTS

Storage	2	Economizer Application/Operation ...	14
General	2	Auto Dry Cycle	14
Installation	3	Start Up Checks	15
Lifting	3	Fan wheel	15
Unit Weights	3	Fan RPM	16
Recommended Roof Openings	3	Energy Recovery Wheel	16
Roof Curb Mounting	4	Coils	17
Duct Work Connections	4	Routine Maintenance	17-18
Weatherhoods	4	Belts	17
Electrical	5	Motors	17
Service Clearances	6	Blower Wheel and Fasteners	17
Evaporative Cooling Modules	7-10	Vibration	18
Evap Module Start-Up	7	Filters	18
Water Control Options	8	Coil Maintenance	19
Trouble Shooting	9	Energy Recovery Wheel Maint	20
Maintenance	10	Accessing Energy Recovery Wheel ...	20
Water Coil Recommendations	11	Removing Wheel Segments	21
Electric Heater Application/Operation	12	Cleaning Wheel Segments	21
Frost Control Application/Operation	13	Parts List	22
Dirty Filter Switch Operation	13	Unit Trouble Shooting	23-24

STORAGE

When a unit is not going to be in service for an extended amount of time, certain procedures should be followed to keep the fans in proper operating condition.

- Rotate fan wheel monthly and purge grease from bearings once every three months
- Cover unit with tarp to protect from dirt and moisture (Note: do not use a black tarp as this will promote condensation)
- Energize fan motor once every three months
- Store belts flat to keep them from warping and stretching
- Store unit in location which does not have vibration
- After storage period, purge grease from fan bearings before putting fan into service

If storage of unit is in a humid, dusty or corrosive atmosphere, rotate the fan and purge the bearings once a month. Improper storage which results in damage to the unit or components will void the warranty.

GENERAL

Greenheck Energy Recovery units with Tempering are thoroughly inspected and test run at the factory. However, damage may occur during handling and shipping. Consequently, it is important to inspect the unit for visible and concealed damage before beginning installation. Report any damage to the shipper immediately. In addition, assure all accessory items are present. Some accessory items are stored inside the unit during shipping. Care must be taken during installation to prevent damage to units.



INSTALLATION

The system design and installation should follow accepted industry practice, such as described in the ASHRAE Handbook.

Adequate space should be left around the unit for piping coils and drains, filter replacement, and maintenance. Sufficient space should be provided on the side of the unit for routine service and component removal should that become necessary.

See pages 6 and 7 for more detail on appropriate clearances.

LIFTING

Units must be lifted as it ships from the factory. All units are equipped with lifting lugs. **THE USE OF ALL LIFTING LUGS IS MANDATORY WHEN LIFTING.** Lifting should only be done with all access doors closed to avoid damaging the unit. To prevent damage to the unit cabinetry, use spreader bars. Spreader bars must be in position to stop cables from rubbing the frame or panels. Before hoisting into position, test lift to insure stability and balance. Avoid twisting or uneven lifting of the unit. Never lift units by weatherhoods.

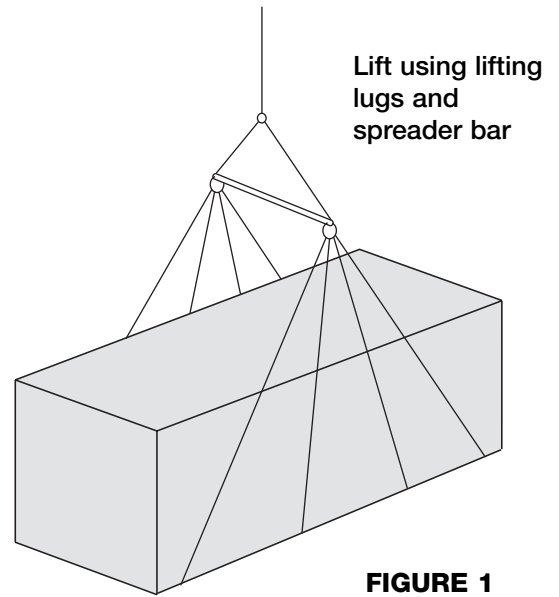

FIGURE 1

UNIT WEIGHTS (dry weights)

Unit Size	Approx. Weight (lbs)
HRE-20	1500
HRE-45	2300
HRE-55	3000
HRE-90	5000

RECOMMENDED ROOF OPENING

Model	U	V
HRE-20	46	37
HRE-45	54	39
HRE-55	65	47
HRE-90	85	49

All dimensions shown are in inches.

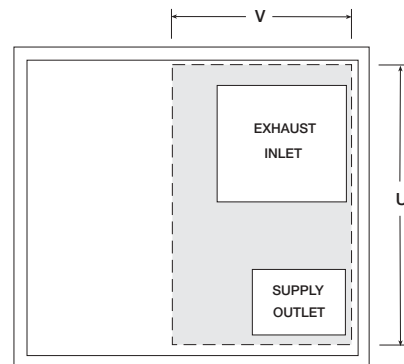

FIGURE 2

ROOF CURB MOUNTING

1. Factory Supplied Roof Curbs

Roof curbs are Model GKD, which are shipped in a knockdown kit and require field assembly (by others). Assembly instructions are included with the curb.

2. Cut Roof Opening and Locate Curb

Layout the unit roof opening such that the supply discharge & exhaust inlet of the unit will line up with the corresponding ductwork (refer to Recommended Roof Openings on page 3). Be sure to allow for the recommended service clearances. Keep the supply inlet of the unit away from any other exhaust fans.

3. Install Curb

Locate curb over roof opening and fasten in place. Check that the diagonal dimensions are within $\pm 1/8$ inch of each other and adjust as necessary. Shim as required to level. Lower unit onto curb by following the *LIFTING* instructions on page 3 of this manual. Note, roof curbs fit inside the unit base.

Curb Outside Dimensions		
Model	L	W
HRE-20	93	51
HRE-45	100.5	60.63
HRE-55	112.75	71.5
HRE-90	125.75	90.75

4. Install Duct Work

Installation of all ducts should be done in accordance with SMACNA and AMCA guidelines.

All dimensions shown are in inches.

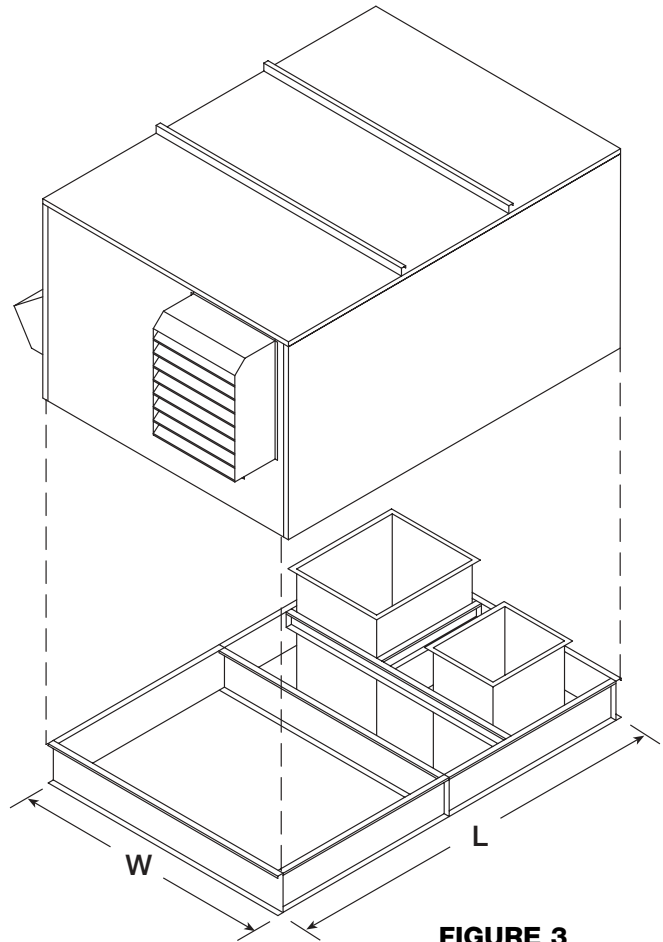

FIGURE 3

DUCT WORK CONNECTIONS

Examples of good and poor fan-to-duct connections are shown below (See FIGURE 4). Airflow out of the fan should be directed straight or curve the same direction as the fan wheel rotates. Poor duct installation will result in low airflow and other system effects.

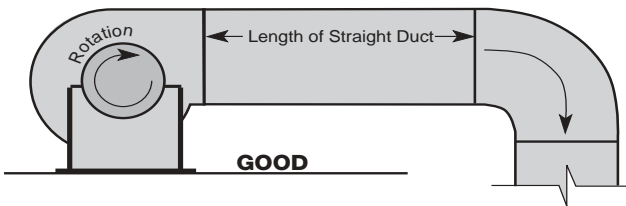
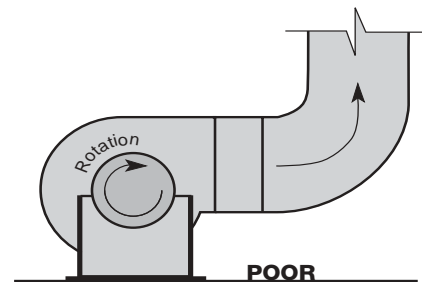

FIGURE 4



SUPPLY WEATHERHOOD

Supply weatherhood will be factory mounted.

EXHAUST WEATHERHOOD

The exhaust weatherhood is shipped separately as a kit with its own instructions.

EXHAUST DAMPERS

Backdraft dampers for exhaust discharge are mounted in the unit. Motorized dampers are shipped loose (inside HRE) and must be field installed.

INSTALLATION (continued)

ELECTRICAL CONNECTIONS

The electrical supply must be compatible with that shown on the nameplate: voltage, phase, and amperage capacity. The electrical supply line must be properly fused and conform to local and national electrical codes.

All internal electrical components are pre-wired at the factory. Field electrical connections only need to be made inside the unit to the main disconnect (See FIGURE 5, Item #1) and the 24 volt control circuit (See FIGURE 5, Item #7). A door interlocking safety disconnect is provided as standard feature.

Note: Standard factory installed electric post heaters have their own disconnect separate from the unit disconnect. Thus, electric post heaters require a separate power connection.

IMPORTANT: Use minimum 14 ga. wire for 24 volt control power. Control wire resistance should not exceed 0.75 ohms (approximately 285 feet total length for 14 ga. wire; 455 feet total length for 12 ga. wire). If wire resistance exceeds 0.75 ohms, an industrial-style, plug-in relay should be added to the unit control center and wired in place of the remote switch (between terminal blocks 2 and 3 on the control strip — See FIGURE 5, Item #7). The relay must be rated for at least 5 amps and have a 24 Vac coil. Failure to comply with these guidelines may cause motor starters to “chatter” or not pull in which can cause contactor failures and/or motor failures.

TYPICAL CONTROL CENTER COMPONENTS

1. Main Disconnect
2. Motor Starter — Exhaust/Scavenger Air Fan
3. Motor Starter — Outdoor Air Fan
4. Motor Contactor — Energy Wheel
5. Control Power Transformer (24 VAC Secondary)
6. Energy Wheel Motor Transformer (230 VAC Secondary) (for HRE-20 & HRE-45 units with primary voltage greater than 230 Vac)
7. 24 VAC Terminal strip
8. Fuses for the control circuit, wheel drive transformer, and blower motors.

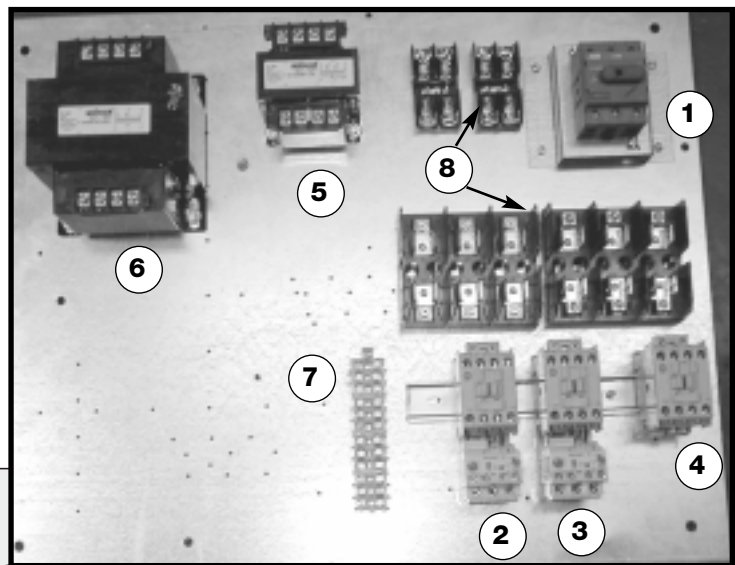
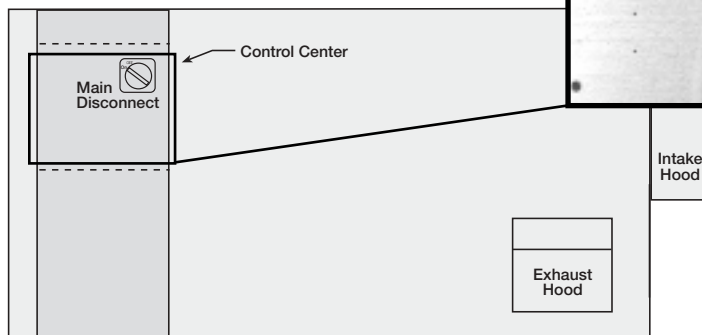
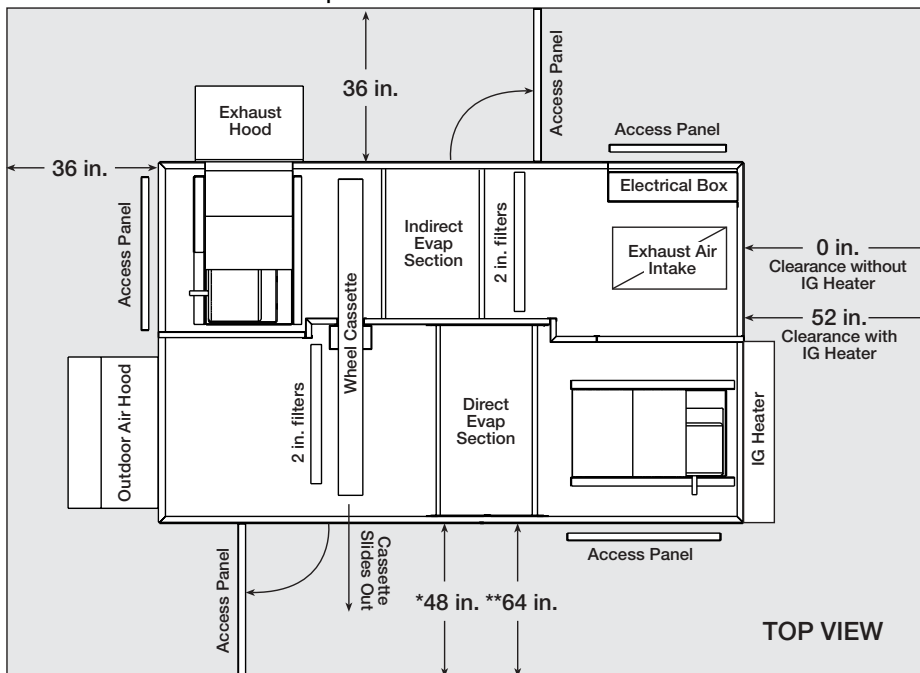

FIGURE 5

SERVICE CLEARANCES / ACCESS PANEL LOCATIONS for Model HRE

HRE-20, 45, 55, and 90 units require minimum clearances for access on all sides for routine maintenance. Filter replacement, drain pan inspection and cleaning, energy wheel cassette inspection, fan bearing lubrication and belt adjustment, are examples of routine maintenance that must be performed. Blower and motor assemblies, energy recovery wheel cassette, coil and filter sections are always provided with a service door or panel for proper component access. *Clearances for component removal may be greater than the service clearances, refer to FIGURES 6 and 7 below for these dimensions.*

Clearances for service and component removal on HRE-20 and HRE-45



*Clearance for energy wheel removal on HRE-20.

**Clearance for energy wheel removal on HRE-45.

FIGURE 6

Clearances for service on HRE-55 and HRE-90

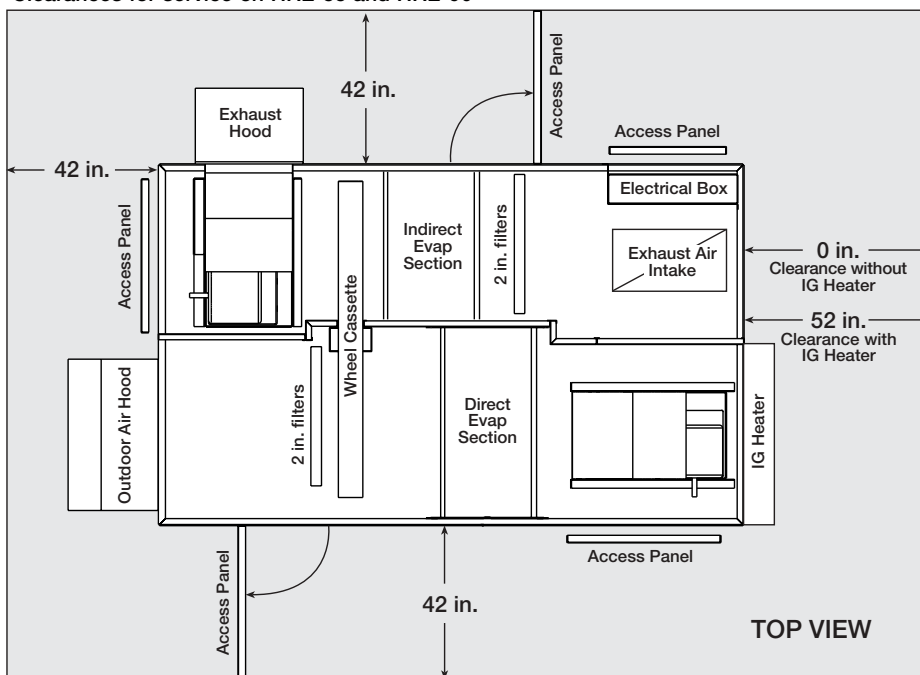

FIGURE 7

Evaporative Cooling Modules

It is important to mount the heat recovery unit level to ensure proper operation and water drainage. Piping should be of adequate size to provide sufficient supply of water to meet the maximum demand of the evaporative coolers.

Evap Module Start-Up

1. After the energy recovery unit is set in place, run the overflow and drain lines to the exterior fittings on the evaporative cooler (drain & overflow connections at unit are 3/4-inch female pipe thread). The supply line can be attached at the downstream side of the evaporative cooler. A manual shut off valve should be mounted in the supply line near the unit for servicing purposes. Also, a trap should be installed in the drain line to prevent sewer gas from being drawn into the unit (see Figure 8).
2. The cooler will be prewired by the factory.
3. Check to make sure that the pump filter is around the pump inlet.
4. Turn the water on and allow the pan to fill up with water. The float should be adjusted to provide 2 inches of water depth in the sump.
5. Saturate the media without any airflow through the unit. A jumper wire is required on the terminal strip to provide power to the evaporative cooler pump (see the wiring diagram for the proper location). This saturation process will break-in the media and minimize the odors associated with the media. The media's break-in period should be no less than 20 minutes. When the process is complete, remove the jumper wires in the control center.

Note: Evaporative media may foam for a short period following the initial start-up. Leave the bleed-off valve fully open until the foaming stops.

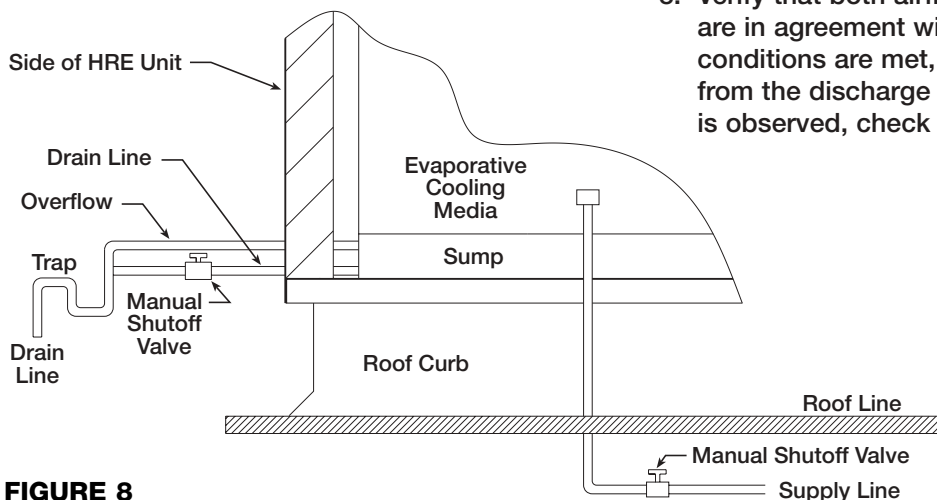
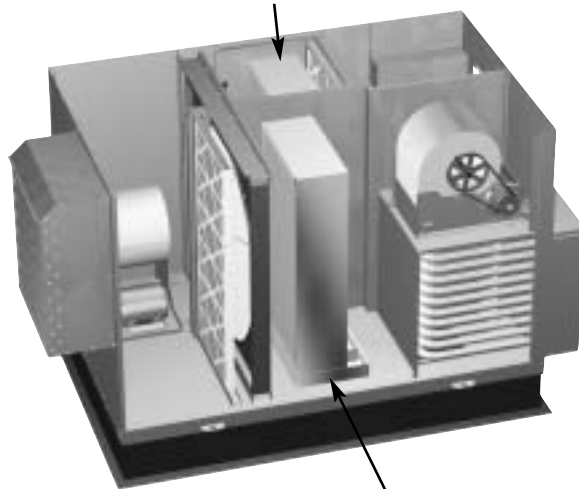

FIGURE 8

Indirect Evaporative Cooler (Exhaust/Scavenger Airstream)



Direct Evaporative Cooler (Outdoor/Supply Airstream)

6. After the media break-in period, the water flow rate over the media needs to be checked. The pumps should provide enough water to saturate the media in 1-3 minutes. If adequate flow rate is not achieved, consult with the factory.
7. The water bleed-off rate will now need to be adjusted. This measurement is 3 to 6 percent of the media flow rate. The recommended flow rate is 1½ to 2 GPM per square foot of media pad top area (see table at right). After the unit has been installed and running for two weeks the unit should be checked for mineral deposits. If there are deposits, the bleed-off rate needs to be increased. Some areas of the country have water with greater amounts of dissolved minerals requiring a higher bleed-off rate.
8. Verify that both airflow and system static pressure are in agreement with the specifications. If these conditions are met, check for water carry over from the discharge side of the media. If carry over is observed, check the distribution header for holes or tears and the water standoff tube for blockage.
9. After all final adjustments are made, remove the jumper wires and replace all access panels. The unit is now ready for operation.

Unit Size	Media Pad Top Area
HRE-20	1.5 ft ²
HRE-45	2 ft ²
HRE-55	2.5 ft ²
HRE-90	3.3 ft ²

WATER CONTROL OPTIONS FOR EVAPORATIVE COOLING

Auto Drain and Fill with Freeze Protection

This system will automatically drain the sump tank and fill it with fresh water at the field adjustable intervals, typically once every 24 hours. This flushes mineral build-up and debris from the tank to promote low maintenance and increase media pad life. In addition, the system will protect the evaporative cooler from freezing by draining the sump tank and supply line when the outside temperatures fall below the set point of the outside air sensor. Typically, this is set at 45° to 50° F. The auto drain and fill control box should be installed in an area that is shaded from direct sunlight so the outside air sensor probe will detect an accurate air temperature.

Plumbing (see FIGURE 9)

1. Run water supply line to the unit and install **Water Supply Solenoid Valve (A)** in this line as close to the water source as possible.
2. Install **Drain Solenoid Valve (B)** in the supply line as indicated below. From the outlet on the drain valve, run line to a suitable drain location.
3. Run an unobstructed drain line from the sump overflow to the drain as shown below.
4. Install **Sump Drain Solenoid Valve (C)** in the drain line from the sump as indicated below. From the outlet on this drain valve, run a line to a suitable drain location.

Note: Water Supply Solenoid Valve (A) is not the same as the Drain Solenoid valves (B) and (C). Make sure to use the proper valve for each location. Check your local code requirements for proper installation of this type of system. Additional drain and supply plumbing may be needed to meet your local code.

Caution: All solenoid valves A, B, and C must be installed below the roof to protect the supply water line from freezing. If these valves cannot be installed below the roof, an alternate method must be used to protect these lines from freezing.

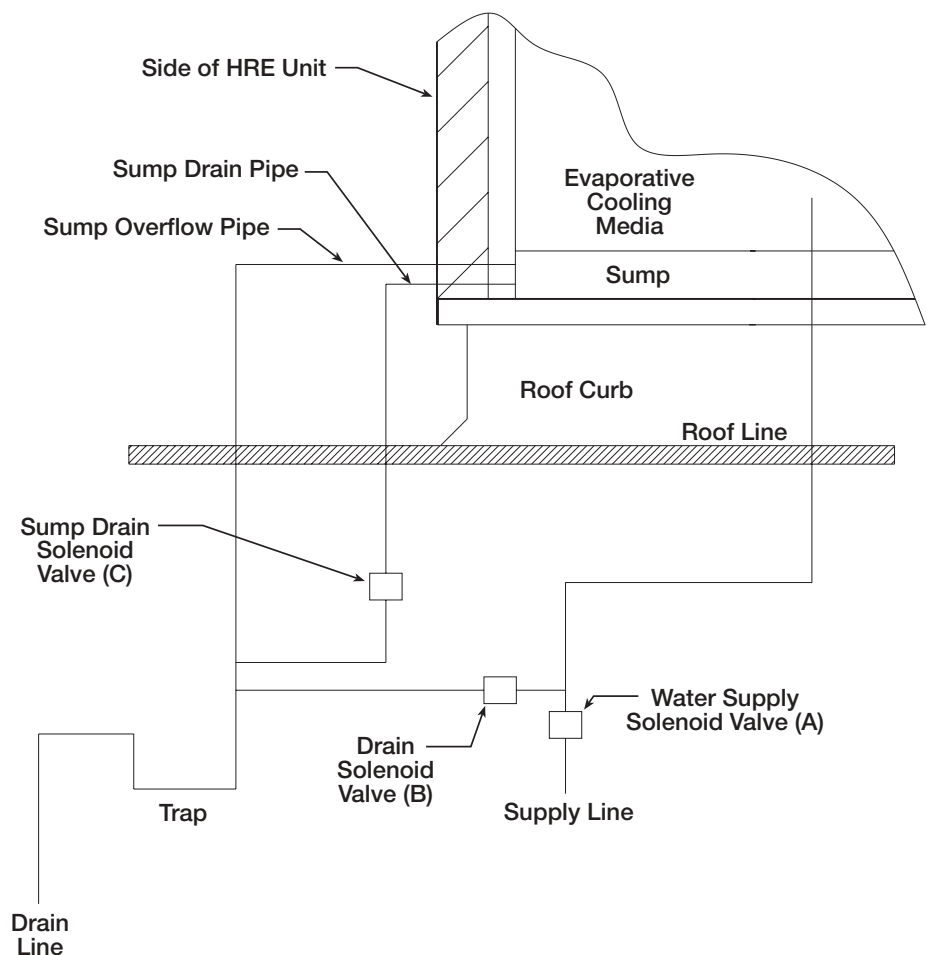

TROUBLE SHOOTING FOR EVAPORATIVE MODULE

Symptom	Solution
Insufficient water volume or recirculation pump not operating	<p>A. Check water level in base pan. The level should be at 2 inches.</p> <p>B. Check the pump filter at the inlet. Clean the filter if clogged or dirty.</p> <p>C. If pump is not operating, check wiring for loose connections and proper voltage.</p>
Irregular water distribution on cooling media	<p>Water distribution header, orifices or media partially blocked or plugged.</p> <p>Remove evaporative cooler from unit.</p> <p>Disassemble and clean distribution header, orifices and media.</p>
Scale and mineral deposit formation on face of media	<p>A. Check water flow across the face of the media. Irregular water distribution must be corrected (see above)</p> <p>B. Increase water flow rate. Media is self cleaning with flow rate of 1½ to 2 gpm per square foot of media top area. Generally this flow rate prevents dissolved solvents from collecting on the media. To prevent further trouble, flush and clean the system more frequently.</p> <p>C. If this condition persists, chemicals may need to be added. Water pH should be maintained between 6 and 8.</p>
Water Carry-Over	<p>A. Irregular water distribution on face of media (see above).</p> <p>B. Average face velocity exceeds 650 fpm. Decrease fan rpm and airflow.</p> <p>C. Localized face velocities exceeding 650 fpm. Air filters or media face area is partially blocked. Clean or replace air filters and media.</p> <p>D. Check the overflow for blockage.</p>
Inadequate cooling	<p>A. Irregular water distribution over face of media (see above).</p> <p>B. Check for uniform air flow.</p> <p>C. Check outside wet-bulb temperature. High wet-bulb temperatures can decrease performance.</p> <p>D. Check water flow rate over media. Flow rate should be 1½ to 2 gpm per square foot of media top area.</p>
Excessive water discharge into drain	<p>A. Check the water bleed off rate and make sure that it is not excessive.</p> <p>B. Check water level in base pan. The level should be at 2 inches.</p>
Poor performance after cooling pad replacement	<p>Pad installed backwards. To get the performance from the cooling pads, they must be installed properly. The pads are manufactured with 15/45 degree flute angles. The pads must always be installed with the steeper flute angle sloping down toward the entering air side. See figure on right.</p>

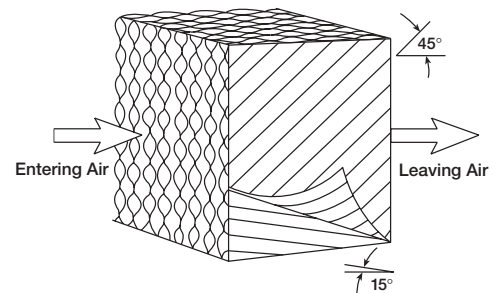

EVAPORATIVE COOLING MAINTENANCE

Regularly scheduled maintenance is the key to peak performance, minimized cost, and extended life of the evaporative cooler. The following is a checklist of items that need to be looked at on a regular basis.

1. The media should be checked for mineral and foreign material deposits that have built up. If these items are left on the media, the life and performance of the unit will be greatly reduced. Also, there are risks of water carry over when this type of condition exists. When signs of mineral build-up are noticed, you should increase the bleed off rate. If this does not solve the problem, chemicals may need to be added to the water. The evaporative pads tend to be self cleaning. Depending on water quality and system maintenance, the useful life of the pads should be 3 to 5 years.
2. The media should be periodically brushed lightly with a soft bristle brush in an up and down motion (never brush side-to-side) while flushing with water. This will also aid in reducing the amount of foreign material build-up.
3. The water should be shut off and all the lines drained when the temperature drops below 50°F.
4. When the evaporative cooler is going to be used for the first time each season, it is recommended that the media be flushed with clean water for a period of 2 minutes (see Evap Module Start-Up on page 7).
5. At the beginning of each cooling season, the upright recirculating pump should have the shaft oiled and spun to eliminate the potential of seizing and pump burn out.
6. If the cooling media was removed from the unit, check to make sure that is not installed backwards. If the media is installed backwards, there will be large amounts of water carry over downstream of the evaporative cooler.
7. At the end of each cooling season the evaporative cooler should be thoroughly cleaned. A dispersant and biocide (consult water treatment consultant for suitable materials and dosage levels) should be recirculated for 12 to 24 hours prior to performing the following steps:
 - a) Disconnect power to unit.
 - b) Shut off all water to the unit
 - c) Open evaporative cooling section door
 - d) Flush distribution headers and media for 20 minutes
 - e) Turn off pumps and drain all water distribution piping, headers, etc.
 - f) Dry media completely by running blowers.
 - g) Brush media as described in Paragraph 2 and perform steps d and e again.
 - h) Clean all remaining components (i.e. sump, pump, etc.) of any mineral deposits or foreign materials
 - i) Replace all worn or non-functioning parts
 - j) Reassemble the cooling unit.
 - k) Close cooling section door.
 - l) Turn the main disconnect 'ON', leaving the cooling switch in the 'OFF' position.
8. If the evaporative cooler will be turned off during the cooling season for an extended period of time, it is recommended that the media be dried out. This can be accomplished by allowing the blowers to continue to run for 1-2 hours. Doing so, will prevent organic build-up on the media and subsequent odors getting into the space.
9. Media should be permitted to dry once per week by allowing the blowers to run for 1-2 hours.
10. A flush cycle should be performed weekly for one hour with the fans off.

Continuous operation in this manner may cause serious damage and void the warranty.

WATER COIL APPLICATION RECOMMENDATIONS

Factory installed heating components are mounted down stream of the energy wheel (and direct evaporative cooler if supplied) on the supply air side of the unit.

See FIGURE 10 for coil connection location. Coil connections are located external to the unit as shown. Coil connections that are not external have been ordered from the factory with interior or exhaust air stream coil connections.

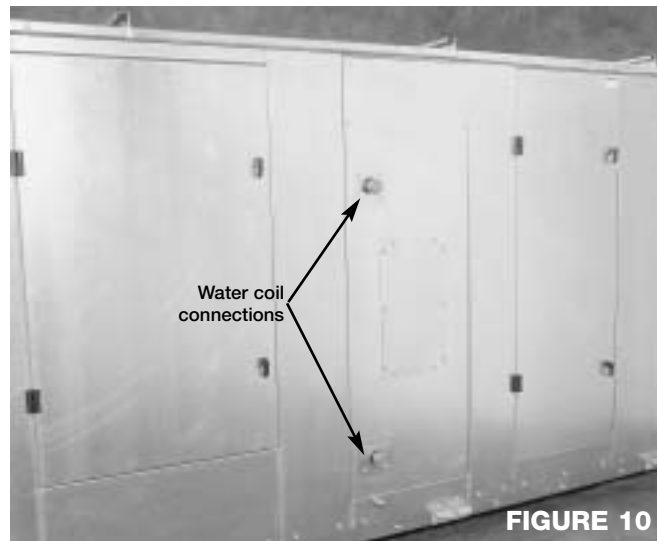

1. Piping should be in accordance with accepted industry standards. Pipework should be supported independently of the coils. Water connections are male NPT iron pipe. When installing couplings, do not apply undue stress to the connection extending through the unit. Use a backup pipe wrench to avoid breaking the weld between coil connection and header.
2. Connect the **WATER SUPPLY TO THE BOTTOM CONNECTION** on the air leaving side and the **WATER RETURN TO THE TOP CONNECTION** on the air entering side. To insure proper venting, an external air vent in the piping is recommended. Connecting the supply and/or return in any other manner will result in very poor performance. Be sure to replace factory installed grommets around coil connections if removed for piping. Failure to replace grommets will result in water leakage into the unit and altered performance.
3. The air vent at the uppermost point should be temporarily opened during system start-up to release all of the air from the coil. To maintain heat transfer capacity, periodically vent any air in coil.
4. Water coils are not normally recommended for use with entering air temperatures below 40°F; however, the energy recovery wheel maintains a pre-coil temperature higher than 40°F. No control system can be depended on to be 100% safe against freeze-up with water coils. Glycol solutions or brines are the only safe media for operation of water coils with low entering air conditions.

CONTINUOUS WATER CIRCULATION THROUGH THE COIL AT ALL TIMES IS HIGHLY RECOMMENDED.
5. Pipe sizes for the system must be selected on the basis of the head (pressure) available from the circulation pump. The velocity should not exceed 6 feet per second and the friction loss should be approximately 3 feet of water column per 100 feet of pipe.

ELECTRIC HEATER APPLICATION/OPERATION

Factory installed electric heaters can be provided for preheat and/or post-heat (see FIGURE 11). An electric preheater warms the outdoor air prior to the energy recovery wheel to prevent frosting on the wheel. An electric post-heater warms the air leaving the energy recovery wheel to a user specified discharge temperature. Electric heaters are available in 208, 230, or 460 Vac (refer to heater nameplate for voltage).

Preheaters: Preheaters are standard as 2-stage, step control. Step control heaters are designed with multiple stages made up of equal increments of heating capability. For example, a 10 kW heater with two stages will be composed of two 5-kW stages. Preheaters are single point wired at the factory. A temperature sensor (with field adjustable set point) is mounted in the outdoor airstream after the preheater to turn the preheater on. See FROST CONTROL APPLICATION/OPERATION for typical set points. If the outdoor air temperature falls below the set point, the first stage of the preheater will turn on. If the first stage does not satisfy the set point, the second stage will also turn on.

Post-heaters: Post-heaters are standard as 4-stage, step control. Post-heaters are not single point wired (see **ELECTRICAL CONNECTIONS**, page 5). The functionality of a 4-stage heater is the same as the 2-stage preheater above, except it has an additional two stages of heat control.

Post-heaters supplied with Greenheck temperature control package are 3-stage with binary control that provides 7 steps of heating. For example, a 35 kW heater with three stages will be composed of 5, 10, and 20 kW stages. The stages essentially ‘mix and match’ to provide heat output from 5 kW to 35 kW, in 5 kW increments.

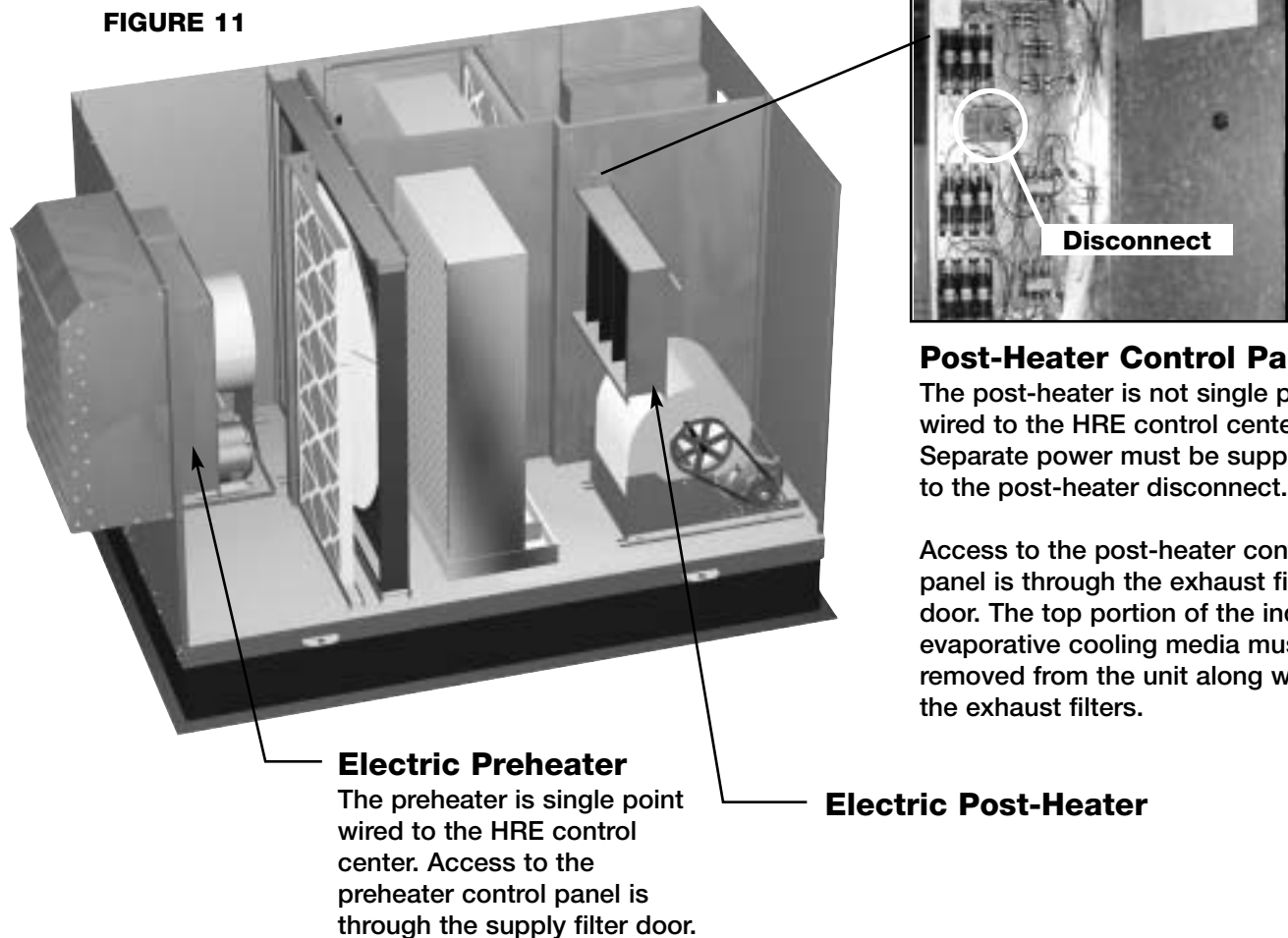

FROST CONTROL APPLICATION/OPERATION

When outdoor air temperatures are extremely cold, moisture condensation and frosting on the energy recovery wheel is possible. Frost control is an optional feature that will prevent wheel frosting. Two options are available:

- 1) Timed Exhaust frost control and
- 2) Preheat frost control

Timed exhaust frost control includes a thermostat (with probe) mounted in the supply air inlet compartment (see FIGURE 13, page 14) and a timer (Figure 12) mounted in the HRE control center. The thermostat will turn on the timed exhaust frost control feature at a predetermined field adjustable outdoor air temperature (referred to as the Frost Threshold temperature). The typical temperature setting corresponds to the indoor air relative humidity as shown in TABLE 1.

Indoor RH @ 70°F	Frost Threshold Temp
20%	2°F
25%	7°F
30%	14°F

TABLE 1

Testing (refer to FIGURE 12)

- Set the **Timer Scale** for T1 and T2 to 1 minute. Set the **Timer Settings** for T1 and T2 to 1.0. Set the dip switch to the down position.
- Turn the temperature sensor up as high as possible. The supply blower should cycle on for one minute, then turn off for one minute.
- After testing, set the **Timer Scale** as follows: T1 = 10 minutes, T2 = 1 hour
- Set the **Timer Settings** as follows: T1 = 0.5, T2 = 0.5. The timer is now set for 5 minutes off and 30 minutes on.

Preheat frost control (see FIGURE 11, page 12) includes a thermostat (with probe) and an electric heater located in the supply air inlet compartment and an air pressure switch in the supply air outlet compartment. The thermostat should be set according to the Frost Threshold temperatures shown in TABLE 1. When the outdoor air temperature reaches the thermostat setting, the electric preheater will turn on and warm the air entering the energy wheel.

Testing

- Turn the thermostat as high as it will go. The heater should turn on.
- If it doesn't, either put the supply side doors on or temporarily jumper the air pressure switch to avoid nuisance tripping of the pressure switch.
Remember to remove the jumper.

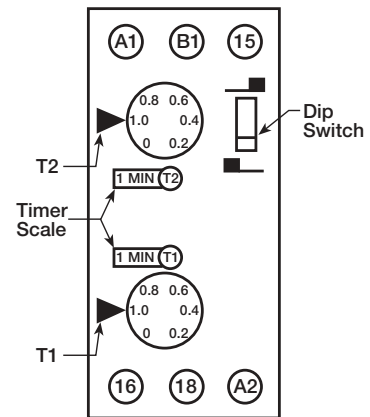

FIGURE 12

DIRTY FILTER SWITCH SETUP

This unit may be equipped with a dirty filter switch that functions on differential air pressures to close a relay when the unit filters are clogged and need cleaning. This switch has not been set at the factory due to external system losses that will affect the switch. This switch will need **minor field adjustments** after the unit has been installed with all ductwork complete. The dirty filter switch is mounted in the exhaust inlet compartment next to the electrical control center.

To adjust the switch the unit must be running with all of the access doors in place, except for the compartment where the switch is located (exhaust inlet compartment). Remove the switch cover plate. The adjusting screw is located on the top of the switch. Open the filter compartment and place a sheet of plastic or cardboard over 50% of the filter media. Replace the filter compartment door. Check to see if there is power at the alert signal leads (refer to electrical diagram). If there is no power, turn the adjustment screw on the dirty filter gage clockwise until you have power. Open the filter compartment and remove the obstructing material. Replace the door and check to make sure that you do not have power at the alert signal leads. The unit is now ready for operation.

ECONOMIZER APPLICATION/OPERATION

The energy recovery wheel may be de-energized for the purpose of providing economizer (free cooling) operation. This can be achieved with a signal from a Temperature or Enthalpy sensor mounted in the supply air inlet compartment (see FIGURE 13). This Primary sensor will de-energize the energy wheel when the outdoor air temperature (factory default is 65°F) or enthalpy (factory default is the 'D' setting) is below the field adjustable set point. An additional Override temperature sensor is also furnished in the supply air inlet compartment to deactivate economizer mode (see FIGURE 13). The Override (with field adjustable set point) is set at some temperature lower than the Primary sensor (factory default is 50°F). Effectively, the two sensors create a deadband where the energy recovery wheel will not operate and free cooling from outside can be brought into the building unconditioned.

Testing (terminals referenced below are in the unit control center — see FIGURE 5, Item #7)

Temperature sensor with Override

- Turn both Temperature and Override thermostats down as low as they go. The wheel should be rotating.
- Turn the Temperature sensor up as high as it goes, and keep the Override sensor as low as it will go. The wheel should stop rotating.
- Turn both sensors as high as they will go. The wheel should start rotating.
- Set the Temperature sensor to the desired temperature for economizer operation to begin. Set the Override sensor to the desired temperature for economizer operation to end (factory default is 65°F and 50°F, respectively).

Enthalpy sensor with Override

- A factory-installed 620 ohm resistor is connected across terminals SR and +. The Override sensor should be turned down below current temperature in unit. Turn the unit on; LED on the sensor should be off. Check continuity across 2 and 3, there should not be continuity. There should be continuity between terminals 1 and 2.
- Disconnect the 620 ohm resistor from terminals SR and +. LED should turn on. There should be continuity between terminals 2 and 3. There should not be continuity between terminals 1 and 2.
- Turn the Override sensor above current temperature in unit. There should be continuity between terminals 3 and 6. Set the Override sensor to the desired temperature for economizer operation to end (factory default is 50°F).
- Reconnect the factory-installed jumper.

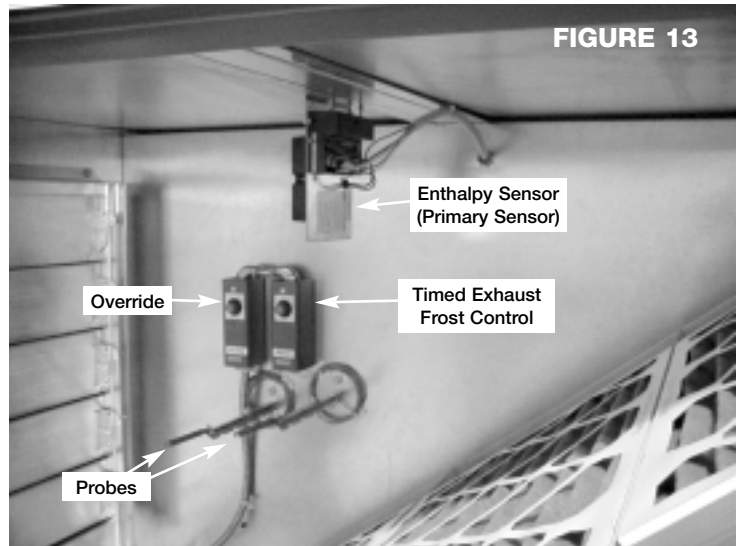

AUTO DRY CYCLE

The HRE may be supplied with a timer to delay turning off the unit to allow the evaporative cooler media pads to dry. The blowers continue to run for a user designated time (factory default is 1.5 hours) following a signal to turn the HRE unit off. The timer is located in the unit control center and can be adjusted from 15 minutes to 3 hours. This option is designed to prevent bacteria/mold growth on the pads. Refer to diagram in unit control center for wiring.

START UP CHECKS

****WARNING****

DO NOT OPERATE ENERGY RECOVERY VENTILATOR WITHOUT THE FILTERS AND BIRDSCREENS INSTALLED. THEY PREVENT THE ENTRY OF FOREIGN OBJECTS SUCH AS LEAVES, BIRDS, ETC.

DO NOT REMOVE ACCESS PANELS OR OTHER UNIT COMPONENTS WHILE STANDING ON A LADDER OR OTHER UNSTEADY BASE. ACCESS PANELS AND UNIT COMPONENTS ARE HEAVY AND SERIOUS INJURY MAY OCCUR.

CAUTION: See ****WARNING**** on page 1 and above

For proper unit function and safety, follow everything in this start-up procedure in the order presented. This to be done after the electrical and gas connections are complete.

Pre-Start Check List

1. Disconnect and lock-out all power switches to fan.
2. Check all fasteners, set screws and locking collars on the fan, bearings, drive, motor base and accessories for tightness.
3. Rotate the fan wheel by hand and assure no parts are rubbing.
4. Check the V-belt drive for proper alignment and tension.

Special Tools Required

- Voltage meter
- Incline manometer or equivalent
- Tachometer
- Thermometer
- Amperage meter

GENERAL

Check all fasteners and set screws for tightness. This is especially important for bearings and fan wheels. Also, if dampers are not motorized, check that they open and close without binding.

FAN WHEEL ROTATION

Hand rotate the blower to ensure that the wheel is not rubbing against the scroll. If the blower is rotating in the wrong direction, the unit will move some air but not perform properly.

To check the rotation, open the blower access panels, which are labeled either supply or exhaust, and run the blower momentarily to determine the rotation. Rotation should be in the same direction as airflow at the outlet (See FIGURES 14 & 15). Check for unusual noise, vibration or overheating of bearings. Refer to the "Trouble Shooting" section of this manual if a problem develops.

To reverse the rotation, turn the power off and use the following procedure:

- For single phase units, rewire the motor per the instructions on the motor.
- For three phase units, interchange any two power leads. (this can be done at the motor starter).

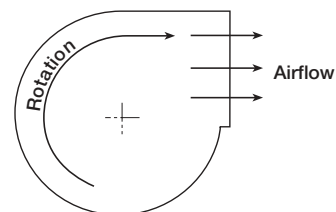

FIGURE 14

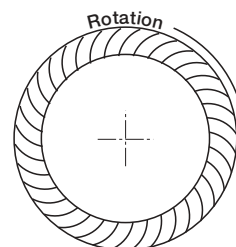

FIGURE 15

Check pulleys and belts for proper alignment to avoid unnecessary belt wear, noise, vibration and power loss. Motor and drive shafts must be parallel and pulleys in line (see FIGURE 16).

FAN RPM

The adjustable motor pulley is preset at the factory to the customer specified RPM. Fan speed can be increased or decreased by adjusting the pitch diameter of the motor pulley. Multi-groove variable pitch pulleys must be adjusted an equal number of turns open or closed. Any increase in fan speed represents a substantial increase in load on the motor. Always check the motor amperage reading and compare it to the amperage rating shown on the motor nameplate when changing fan RPM. Access these components through the labeled access panels.

All access doors must be installed except the control center door. To measure the fan rpm, the blower door will need to be removed. Minimize measurement time because the motor may overamp with the door removed. *Do not operate units with access doors/panels open or without proper ductwork in place as the motors will overload.*

ENERGY RECOVERY WHEEL

CAUTION: See ****WARNING**** on page 1 and 15

For the HRE-20 and HRE-45, open the access door marked "Energy Wheel Cassette Access". UNPLUG the wheel drive motor and remove the metal spacer. Then pull the cassette out halfway as seen in FIGURE 17.

Note: For the HRE-55 and HRE-90, the energy recovery wheel does not slide out due to its size and weight. There is ample room inside the unit to perform energy recovery wheel servicing.

Turn the energy recovery wheel by hand to verify free operation. Check that the air seals, located around the outside of the wheel and across the center (both sides of wheel), are secure and in good condition. Replace cassette into unit, plug in wheel drive, replace access door and apply power. Observe that the standard and high flow wheel rotates freely at about 60 RPM.

If wheel does not rotate or rotates too slowly, remove the cassette (following the instruction on page 20). Air seals, which are too tight, will prevent proper rotation of the energy recovery wheel. Recheck the air seals for tightness. Air seal clearance may be checked by placing a sheet of paper, to act as a feeler gauge, against the wheel face. To adjust the air seals, loosen all eight seal retaining screws. These screws are located on the bearing support that spans the length of the cassette through the wheel center. Tighten the screws so the air seals tug slightly on the sheet of paper.

COILS

Leak test thermal system to insure tight connections.

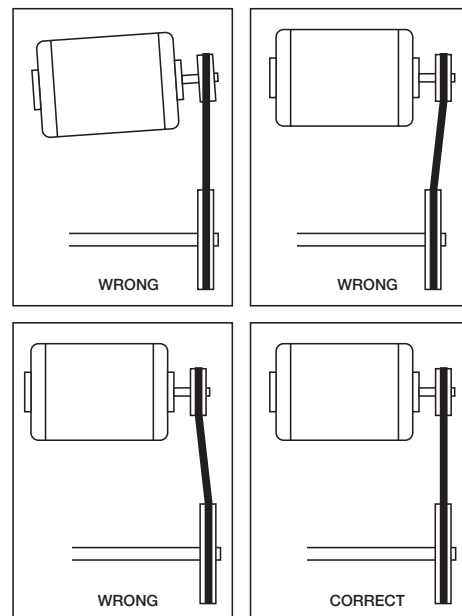

FIGURE 16



FIGURE 17

ROUTINE MAINTENANCE

CAUTION: See ****WARNING**** on Page 1 and 15

Once the unit has been put into operation, a periodic maintenance program should be set up to preserve the reliability and performance. Items to be included in this program are:

- **BELTS**
- **MOTORS**
- **WHEEL AND FASTENERS**
- **VIBRATION**
- **FILTER MAINTENANCE**
- **COIL MAINTENANCE**
- **ENERGY WHEEL CASSETTE**

FAN BELTS

Belts tend to stretch after a period of time. They should be periodically checked for tension and wear. When replacing belts, use the same type as supplied with the unit. Replacement of belts should be accomplished by loosening the motor slide plate so the belts may be removed by hand. Do not force belts on or off as this may cause breakage of cords and lead to premature belt failure.

Belt tension should be adjusted to allow 1/64 in. of belt deflection per 1 in. of belt span. For example, a 16 in. belt span should have 16/64 in. or 1/4 in. of deflection with moderate thumb pressure at mid-point between the pulleys (FIGURE 18).

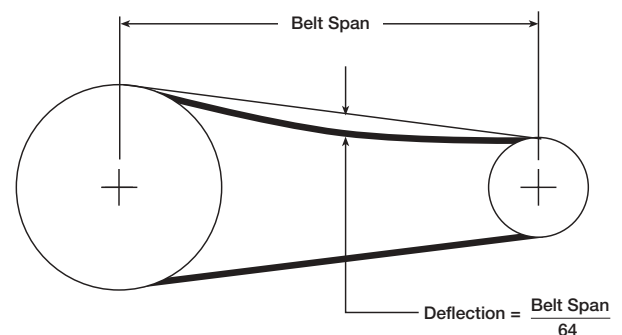

FIGURE 18

MOTORS

Motor maintenance is generally limited to cleaning and lubrication (where applicable). Cleaning should be limited to exterior surfaces only. Removing dust and grease build-up on the motor housing assures proper motor cooling. Use caution and do not allow water or solvents to enter the motor or bearings. Under no circumstances should motors or bearings be sprayed with steam, water or solvents.

Greasing of motors is intended only when fittings are provided. Many fractional horsepower motors are permanently lubricated for life and require no further lubrication. Motors supplied with grease fittings should be greased in accordance with the manufacturer's recommendations.

WHEEL AND FASTENERS

Wheels require very little attention when moving clean air. Occasionally oil and dust may accumulate on the wheel causing imbalance. When this occurs the wheel and housing should be cleaned to assure smooth and safe operation. Inspect fan impeller and housing for fatigue, corrosion or wear.

Routinely check all fasteners, set screws and locking collars on the fan, bearings, drive, motor base and accessories for tightness. A proper maintenance program will help preserve the performance and reliability designed into the fan.

VIBRATION

Excessive vibration may be experienced during initial start-up. Left unchecked, excessive vibration can cause a multitude of problems, including structural and/or component failure. The most common sources of vibration are listed below.

Many of these conditions can be discovered by careful observation. Refer to the troubleshooting section of this manual for corrective actions. If observation cannot locate the source of vibration, a qualified technician using vibration analysis equipment should be consulted. If the problem is wheel unbalance, in-place balancing can be done providing there is access to the fan wheel.

Generally, fan vibration and noise are transmitted to other parts of the building by the ductwork. To eliminate this undesirable effect, the use of heavy canvas connectors is recommended.

1. Wheel Unbalance
2. Drive Pulley Misalignment
3. Incorrect Belt Tension
4. Bearing Misalignment
5. Mechanical Looseness
6. Faulty Belts
7. Drive Component Unbalance
8. Poor Inlet/Outlet Conditions
9. Foundation Stiffness

EXTERNAL FILTER MAINTENANCE

Aluminum mesh 2 in. filters are located in the supply weatherhood (if the weatherhood option was purchased). Filters should be checked and cleaned on a regular basis for best efficiency. The frequency of cleaning depends upon the cleanliness of the incoming air.

To remove these filters, remove bottom bolt in the access door on the side of the weatherhood. Slide the access door up and then pull out. Then, slide the filters out (see FIGURE 19).

Clean filters by rinsing with a mild detergent in warm water. After the filters are dry, an adhesive spray available at most filter distributors may be applied to increase filter efficiency.

INTERNAL FILTER MAINTENANCE

Opening the access doors labeled as "Filter Access" provides access to the pleated 30% filters (if the filter option was purchased). These filters should be checked regularly, cleaned or replaced as needed. See TABLE 2 for pleated filter size and quantity for each unit.

FIGURE 19

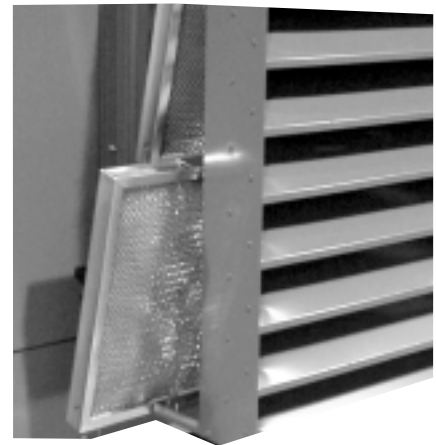

TABLE 2

Model	Internal Filter Size	Quantity
HRE-20	20 x 20	2
HRE-45	20 x 25	3
HRE-55	16 x 25	6
HRE-90	20 x 20	8

WATER COIL MAINTENANCE

CAUTION: See ****WARNING**** on Page 1 and 15

FILTERS

Filters upstream of the coil should be checked regularly. If the filters are dirty, they should be cleaned or replaced. It is important that the coils stay clean to maintain desired airflow. See page 18 for more information on filter maintenance.

COIL MAINTENANCE

1. Coils must be clean to obtain maximum performance. Check once a year under normal operating conditions and, if dirty, brush or vacuum clean. Soiled fins reduce the capacity of the coil, demand more energy from the fan, and create an environment for odor and bacteria to grow and spread through the conditioned zone. High pressure water (700 Psi or less) may be used to clean coils with fin thickness over 0.0095 inches thick. **TEST THE SPRAY PRESSURE** over a small corner of the coil to determine if the fins will withstand the spray pressure.

For coils with fragile fins or high fin density, foaming chemical sprays and washes are available. Many coil cleaners contain harsh chemicals, so they must be used with caution by qualified personnel only. Care must be taken not to damage the coils, including fins, while cleaning.

CAUTION: Fin edges are sharp.

****WARNING****

BIOLOGICAL HAZARD. MAY CAUSE DISEASE. CLEANING SHOULD BE PERFORMED BY QUALIFIED PERSONNEL.

ROUTINE ENERGY RECOVERY WHEEL MAINTENANCE

CAUTION: See ****WARNING**** on Page 1 and 15

MAINTENANCE OF THE ENERGY RECOVERY WHEEL

Annual inspection of the energy recovery wheel is recommended. Units ventilating smoking lounges and other non-clean air spaces should have energy recovery wheel inspections more often based upon need. Inspections for smoke ventilation applications are recommended bimonthly to quarterly until a regular schedule can be established.

ACCESSING ENERGY RECOVERY WHEEL

For the HRE-20 and HRE-45, open the access door marked "Energy Wheel Cassette Access" (FIGURE 20). UNPLUG the wheel drive motor and remove the metal spacer. Then pull the cassette out halfway (FIGURE 21).

The energy recovery wheel cassettes for model HRE-55 and HRE-90 do not slide out due to their size and weight. Service to these energy wheel cassettes can be done through the Filter and Electrical Control Box access doors, or by entering the unit through the Exhaust Blower access door.

****WARNING: Disconnect power to the unit before performing any type of service.****



FIGURE 20

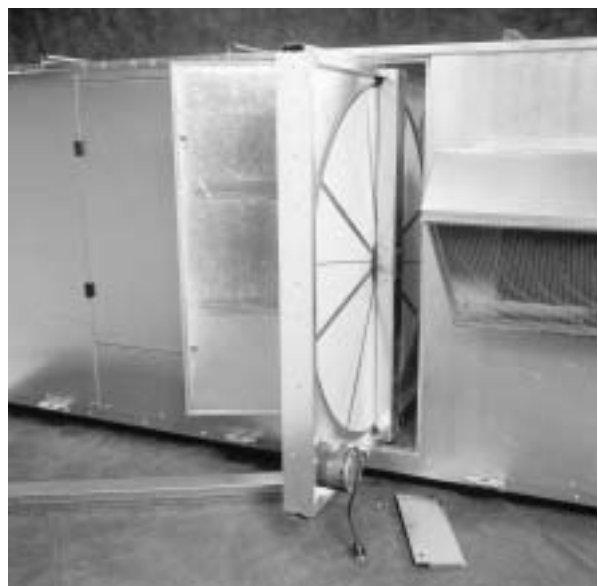

FIGURE 21

REMOVING THE ENERGY RECOVERY WHEEL SEGMENTS

Model HRE-20, 45, 55, & 90

Steel retainers are located on the inside of the wheel rim (FIGURE 22). Push the retainer toward center of wheel, then lift up and away to release segments (FIGURE 23).

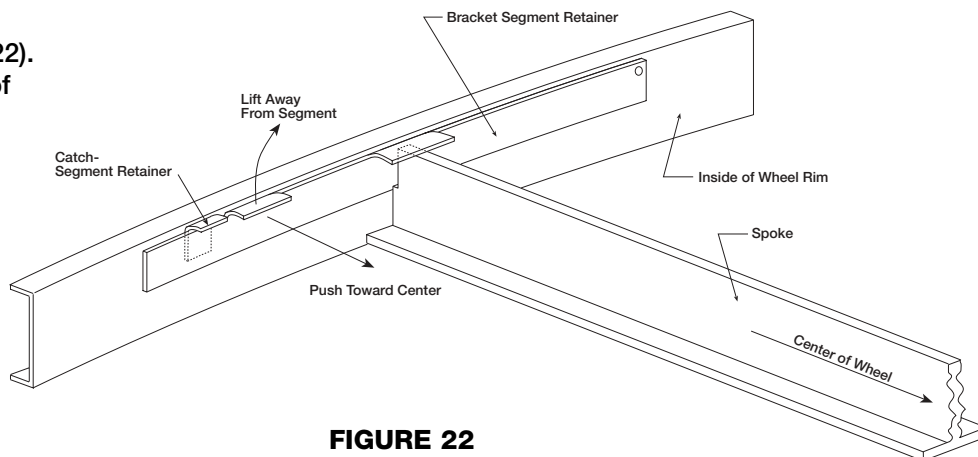

FIGURE 22



FIGURE 23

IMPORTANT! PLACE RETAINERS BACK IN THE ORIGINAL POSITION BEFORE ROTATING THE ENERGY RECOVERY WHEEL. OTHERWISE DAMAGE TO RETAINER WILL OCCUR.

CLEANING ENERGY RECOVERY WHEEL SEGMENTS

If the wheel appears excessively dirty, it should be cleaned to ensure maximum operating efficiency. Only excessive buildup of foreign material needs to be removed. **DISCOLORATION AND STAINING OF ENERGY RECOVERY WHEEL DOES NOT AFFECT ITS PERFORMANCE.**

Thoroughly spray wheel matrix with household cleaner such as Fantastic™ or equivalent. Gently rinse with warm water and using a soft brush remove any heavier accumulation. A detergent/water solution can also be used. Avoid aggressive organic solvents, such as acetone. The energy recovery wheel segments can be soaked in the above solution overnight for stubborn dirt or accumulation.

After cleaning is complete, shake the excess water from the wheel or segments. Dry wheel or segments before placing them back into the cassette. Place wheel or segments back into cassette by reversing removal procedures.

- ** DO NOT CLEAN ENERGY RECOVERY WHEEL SEGMENTS WITH WATER IN EXCESS OF 140°F
- ** DO NOT DRY ENERGY RECOVERY WHEEL SEGMENTS IN AIR IN EXCESS OF 140°F.

PARTS LIST

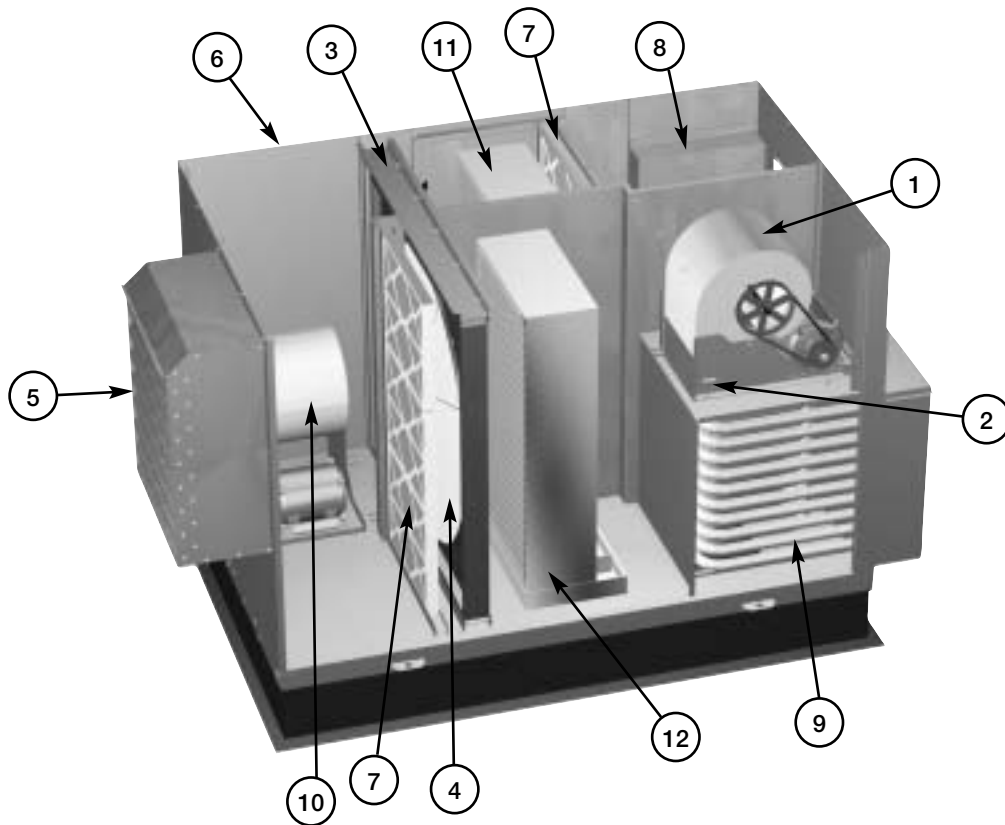

Model HRE

(shown with indirect evaporative cooler,
optional direct evaporative cooler, and
indirect gas heater)

- | | |
|--|--|
| <p>1. Supply blower</p> <ul style="list-style-type: none"> - Forward curved fan - Adjustable motor mount for belt tensioning - Adjustable sheaves for speed control | <p>8. Electrical control box (standard features)</p> <ul style="list-style-type: none"> - Single point power - Disconnect interlocked with access door - Motor starters for the supply blower, exhaust blower and energy wheel motors. - 24 Vac, control circuit with terminal strip |
| <p>2. Vibrations isolators (quantity 4 per blower)</p> <ul style="list-style-type: none"> - Neoprene | <p>9. Supply air tempering options</p> <ul style="list-style-type: none"> - Electric heat - Hot water heat - Indirect gas heat |
| <p>3. Energy recovery wheel cassette</p> | |
| <p>4. Removable energy recovery wheel segments</p> | |
| <p>5. Optional supply weatherhood with 2 in. aluminum mesh filter</p> | <p>10. Exhaust blower</p> <ul style="list-style-type: none"> - Forward curved fan - Adjustable motor mount for belt tensioning - Adjustable sheaves for speed control |
| <p>6. Optional exhaust weatherhood with birdscreen</p> | <p>11. Indirect evaporative cooler</p> |
| <p>7. Optional supply and exhaust air filter racks for 2 in. pleated, 30% efficient filters</p> | <p>12. Direct evaporative cooler</p> |

Trouble Shooting

Symptom	Possible Cause	Corrective Action
Blower Fails to Operate	Blown fuse or open circuit breaker.	Replace fuse or reset circuit breaker and check amps.
	Defective motor or capacitor.	Replace
	Motor starter overloaded.	Reset starter and check amps.
	Electrical. Drive.	Check for On/Off switches. Check for correct supply voltage. Check for broken or loose belts. Tighten loose pulleys.
Motor Starters "Chatter" or Do Not Pull In	Control power (24 Vac) wiring run is too long (resistance should not exceed 0.75 ohms).	Shorten wiring run to mechanical room or install a relay which will turn unit on/off (C/F for relay information).
	Incoming supply power is less than anticipated. Voltage supplied to starter coil must be within +10% / -15% of nominal voltage stated on the coil.	Need to increase supply power or use a special control transformer which is sized for the actual supply power.
Motor Over Amps	Cfm too high.	Check cfm and adjust drives if needed.
	Static pressures are higher or lower than design.	If higher, ductwork should be improved. If lower, fan rpm should be lower.
	Blower rotation is incorrect.	Check rotation and reverse if necessary.
	Motor voltage incorrect.	Check motor nameplate versus supplied voltage.
	Motor horsepower too low.	See specifications and catalog for fan curves to determine if horsepower is sufficient.
	Shorted windings in motor.	Replace motor.
Low Airflow (cfm)	Unit damper not fully open.	Adjust damper linkage or replace damper motor.
	System static pressure too high	Improve ductwork to eliminate losses using good duct practices.
	Blower speed too low.	Check for correct drives and rpm with catalog data.
	Fan wheels are operating backwards.	For 3-phase see Fan Wheel Rotation on page 15.
	Dirty filter or energy wheel.	Follow cleaning procedures on pages 18 and 21.
	Leaks in ductwork.	Repair.
	Elbows or other obstructions may be obstructing fan outlet.	Correct or improve ductwork.
	Belt slippage.	Adjust belt tension.
High Airflow (cfm)	Blower fan speed too high.	Check for correct fan rpm. Decrease fan speed if necessary.
	Filter(s) not in place.	Install filters.
	Insufficient static pressure (Ps) (airflow resistance).	Induce Ps into system ductwork. Make sure grilles and access doors are installed. Decrease fan speed if necessary.

** Always provide the unit model and serial number when requesting parts or service information. * Always check motor amps and compare to nameplate rating.*

Trouble Shooting

Symptom	Possible Cause	Corrective Action
One or Both Blowers Turn Off Intermittently and Back on After About 2 Minutes	Blower fan motor overloads are tripping and auto-resetting.	Decrease fan speed.
	Exhaust Only frost control sensors are tripping.	Adjust frost temperature sensor set point as needed.
Energy Wheel Does NOT Turn	Air seals are too tight.	See Energy Recovery Wheel on page 16.
	“Economizer” sensors are operating.	Adjust temperature or enthalpy set points as needed.
	No power to wheel motor.	Make sure wheel drive is plugged in. Verify power is available.
	Wheel drive belt	Check for loose or broken belts. Replace belts (consult factory).
Energy Wheel Runs Intermittently	Wheel motor overloads are tripping, due to rubbing between wheel and air seals.	Recheck air seals, make sure they are not too tight. See Energy Recovery Wheel on page 16.
Excessive Noise or Vibration	Fan wheel rubbing on inlet	Adjust wheel and/or inlet cone. Tighten wheel hub or bearing collars on shaft.
	Bearings.	Replace defective bearings (s). Lubricate bearings. Tighten collars and fasteners.
	Wheel out of balance.	Replace or rebalance.
	Loose wheel on shaft.	Tighten wheel setscrew.
	Loose motor or blower sheave.	Tighten sheave setscrew.
	Belts too loose.	Adjust belt tension after 24 hours of operation.
	Belts too tight.	Loosen to maintain a 3/8 inch deflection per foot of span between sheaves.
	Worn belt.	Replace.
	Motor base or blower loose.	Tighten mounting bolts.
	Build up of material on wheel.	Clean wheel and housing.
Bearing and drive misaligned.	Realign.	
Noise being transmitted by duct.	Make sure duct work is supported properly. Make sure duct work metal thickness is sized for proper stiffness. Check duct size at discharge to ensure that air velocities are not too high.	

** Always provide the unit model and serial number when requesting parts or service information. * Always check motor amps and compare to nameplate rating.*

Warranty

Greenheck warrants this equipment to be free from defects in material and workmanship for a period of one year from the purchase date. The energy recovery wheel is warranted to be free from defects in material and workmanship for a period of five years from the purchase date. Any units or parts which prove defective during the warranty period will be replaced at our option when returned to our factory, transportation prepaid.

Motors are warranted by the motor manufacturer for a period of one year. Should motors furnished by Greenheck prove defective during this period, they should be returned to the nearest authorized motor service station. Greenheck will not be responsible for any removal or installation costs.

Due to continuing product development Greenheck has the right to change specifications without notice

